

PRODUCT GUIDE

Discrete IGBTs

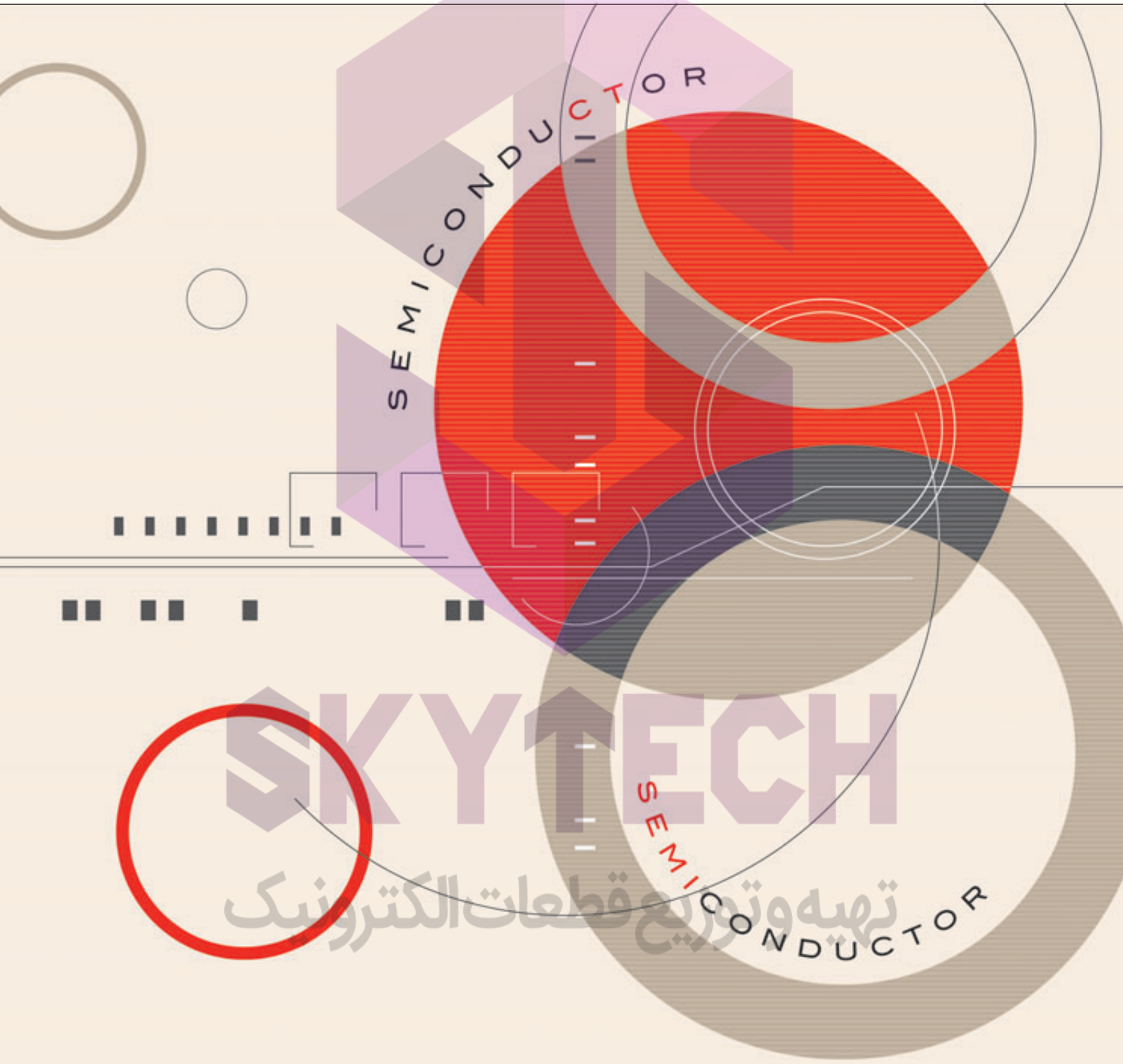

1 Features and Structure

IGBT: Insulated Gate Bipolar Transistor

IGBTs combine the MOSFET advantage of high input impedance with the bipolar transistor advantage of high-voltage drive.

The conductivity modulation characteristics of a bipolar transistor make it ideal for load control applications that require high breakdown voltage and high current.

Toshiba offers a family of fast switching IGBTs, which are low in carrier injection and recombination in carrier.

Features of the Toshiba Discrete IGBTs

The Toshiba discrete IGBTs are available in high-voltage and high-current ratings. They are used in inverter and power conversion circuits for such diverse applications as motor drivers, uninterruptible power supply (UPS) systems, IH cookers, plasma display panels (PDPs), strobe flashes and so on.

- (1) IGBTs also featuring fast switching
- (2) Low collector-emitter saturation voltage even in the large current area
- (3) IGBTs featuring a built-in diode with optimal characteristics tailored to specific applications
- (4) High input impedance allows voltage drives
- (5) Available in a variety of packages

Construction

The basic structure of the planar IGBT consists of four layers (pnpn), as shown in the following figure.

Low saturation voltage is achieved by using a pnp transistor to allow conductivity modulation during conduction.

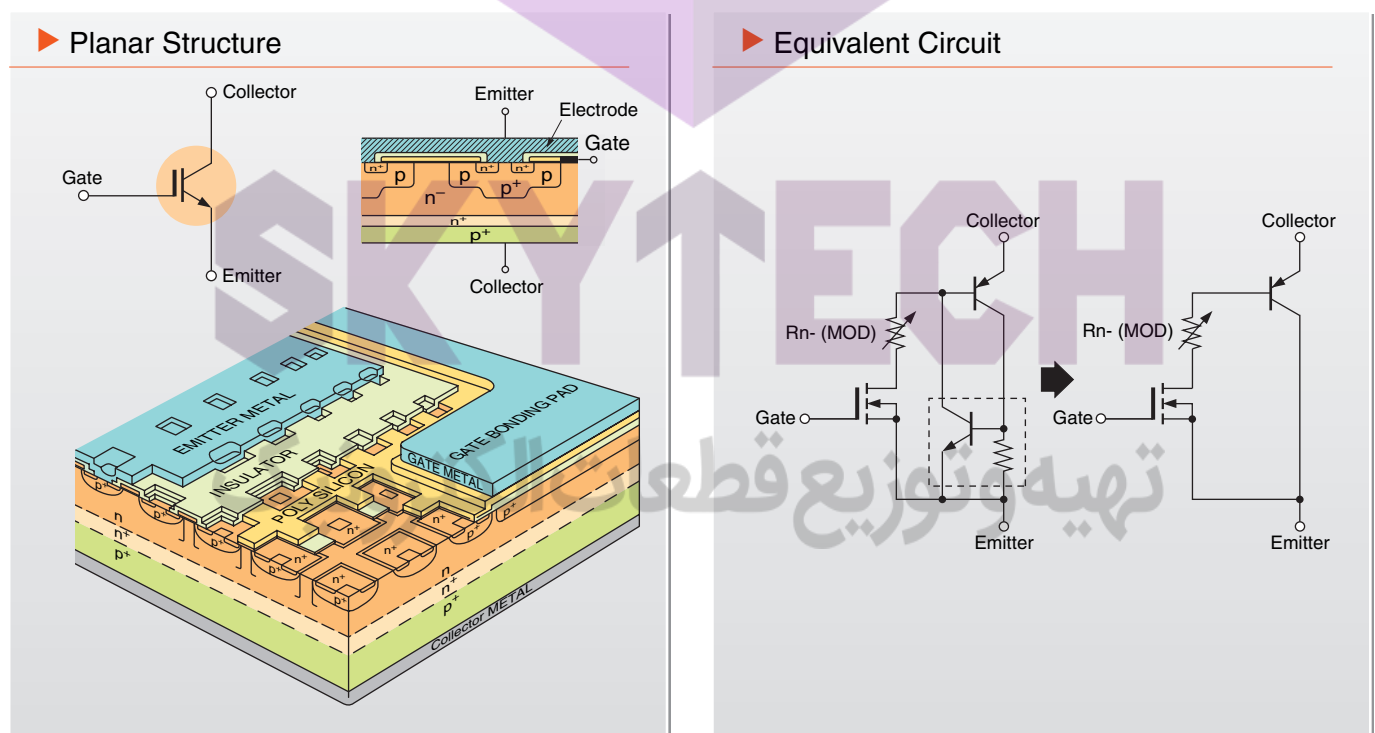

2 IGBT Technical Overview

Prior to the development of IGBTs, power MOSFETs were used for power amplifier applications which require high input impedance and fast switching. However, at high voltages, the on-state resistance rapidly increases as the breakdown voltage increases. It is thus difficult to improve the conduction loss of power MOSFETs.

On the other hand, the IGBT structure consists of a pnp bipolar transistor and a collector contact made on the p⁺ layer. The IGBT has a low on-state voltage drop due to conductivity modulation.

The following figure shows the $V_{CE(sat)}$ curve of a soft-switching 900-V IGBT. Toshiba has offered IGBTs featuring fast switching by using carrier lifetime control techniques. Now, Toshiba offers even faster IGBTs with optimized carrier injection into the collector p⁺ layer.

In the future, Toshiba will launch IGBTs with varied characteristics optimized for high-current-conduction and high-frequency-switching applications. The improvements in IGBTs will be spurred by optimized wafers, smaller pattern geometries and improved carrier lifetime control techniques.

▶ 900-V IGBT for Soft-Switching

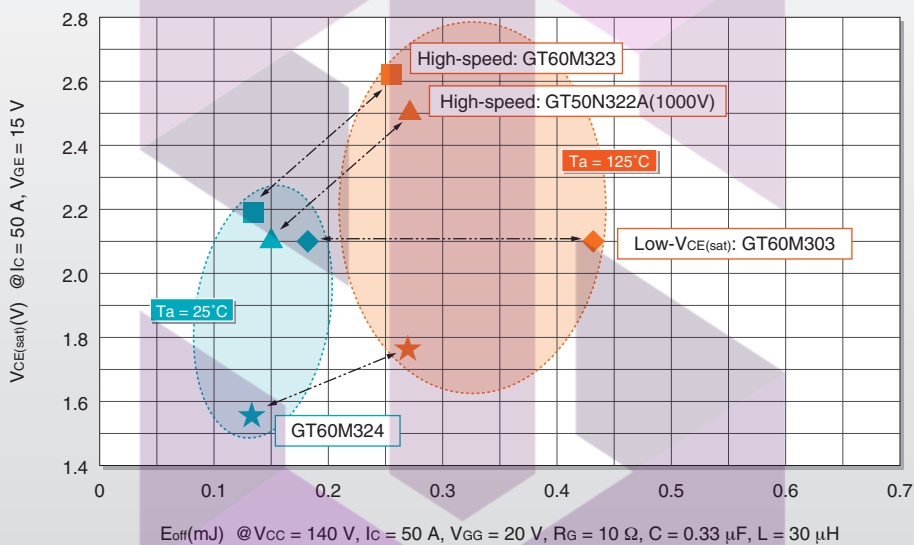

Discrete IGBT Development Trends

Voltage Range	Development Trends
1200 V	(1) High ruggedness (3rd gen): Low $V_{CE(sat)}$ and high ruggedness due to optimized carrier injection and thinner wafers
	(2) Soft switching (5th gen): Low $V_{CE(sat)}$ due to trench gate structure
	(3) Soft switching (6.5th gen): RC structure
900 to 1500 V	(1) Soft switching (4th gen): Low $V_{CE(sat)}$ due to trench gate structure
	(2) Soft switching (5th gen): Low $V_{CE(sat)}$ due to optimized carrier injection and trench gate structure
	(3) Soft switching (6th gen): Thinner wafers and finer process geometries
	(4) Soft switching (6.5th gen): RC structure
600 V	(1) High ruggedness (3rd gen): Low $V_{CE(sat)}$ and high ruggedness due to optimized carrier injection and thinner wafers
	(2) Fast switching (4th gen): High speed t_f due to optimized carrier injection
	(3) Soft switching (4th gen): Low $V_{CE(sat)}$ due to trench gate structure
	(4) Low $V_{CE(sat)}$ (6th gen): Thinner wafers and finer process geometries
	(5) Soft switching (5th gen): Thinner wafers
	(6) Soft switching (6th gen): Thinner wafers and finer process geometries
400 V	(1) Strobe flashes (5th gen): Low $V_{CE(sat)}$ due to trench gate structure
	(2) Strobe flashes (6th gen): High current due to trench gate structure and optimized wafers
	(3) Strobe flashes (7th gen): High current due to optimized wafers and finer process geometries
300 to 400 V	(1) Plasma displays (4th gen): Low $V_{CE(sat)}$ due to trench gate structure and high I_C due to lifetime control
	(2) Plasma displays (5th gen): Low turn-on loss due to finer process geometries
	(3) Plasma displays (6th gen): Low turn-on loss due to optimized wafers and finer process geometries
	(4) Plasma displays (7th gen): Thinner wafers and finer process geometries

Year 2006 2008 2010 2012

3 Discrete IGBT Product Lineup

Applications and Features	Breakdown Voltage V_{CES} (V) @ $T_a = 25^\circ\text{C}$	IGBT Current Rating I_c (A) @ $T_a = 25^\circ\text{C}$		TSON-8	SOP-8	TO-220SIS	TO-220SM(MXN)	TO-3P(N)	TO-3P(N)IS	TO-3P(LH)	
		DC	Pulse								
General-purpose motors General-purpose inverters Hard switching fc: up to 20 kHz	600	10	20					GT10J301 GT20J301 GT20J101			
		20	40					GT30J301 GT30J101			
		30	60								
	1200	50	100								
		10	20					GT10Q301 GT10Q101			
		15	30					GT15Q301 GT15Q102			
25	50								GT50J102		
General-purpose inverters Fast switching Hard switching fc: up to 50 kHz FS series	600	30	60					GT30J324 GT30J121	GT30J126		
		50	100							GT50J325 GT50J121	
Resonant switching Soft switching Soft-Switching Series	600	30	100						GT30J322		
		37	100						GT35J321		
		40	100					GT40J321 GT40J322 GT40J323	GT40J325		
		50	100					GT50J327 GT50J341			GT50J322 GT50J322H
			120					GT50J328			
		60	120								GT60J321 GT60J323 GT60J323H
	900	15	30						GT15M321		
		35	100						GT35MR21		
		50	100					GT50MR21			
		120						GT50M322			
		60	120					GT60M324			
	1000	50	120					GT50N322A GT50N324			GT60N321
		60	120								
		50	100					GT50NR21			
		1200	40	80				GT40QR21			
1500	40	80					GT40T321				
	30	100					GT30J122A	GT30J122			
PFC	600	40	100						GT40J121		
		130									
Strobe flashes	400			GT5G133							
				GT8G151	GT8G132						
					GT10G131						
Plasma display panels	300	200					GT30F124 GT45F127				
	330	200					GT30F125 GT45F128				
	360	200						GT30F131			
	430	200					GT30G124 GT30G125 GT45G127 GT45G128				
	600	200					GT30J124				

 : New product

4 Part Numbering Scheme

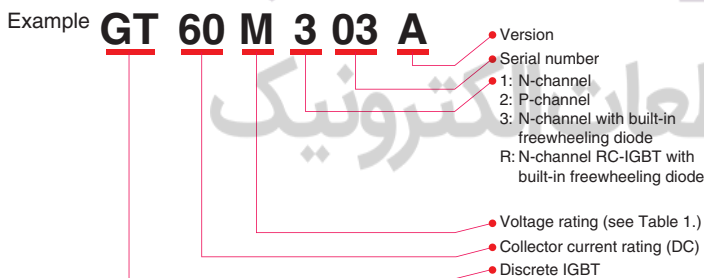

Table 1

Letter	Voltage (V)	Letter	Voltage (V)	Letter	Voltage (V)
C	150	J	600	Q	1200
D	200	K	700	R	1300
E	250	L	800	S	1400
F	300	M	900	T	1500
G	400	N	1000	U	1600
H	500	P	1100	V	1700

5-1 General-Purpose Inverter

The fast-switching (FS) series, a new addition to our third-generation IGBTs, features high ruggedness which helps to improve the energy efficiency of electronic equipment.

General-Purpose Inverters

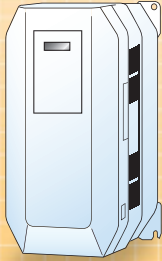

Inverter Air Conditioners

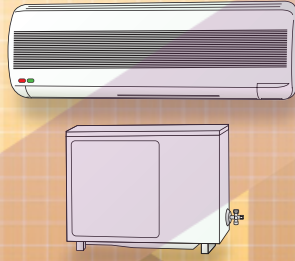

Inverter Washing Machines



UPS

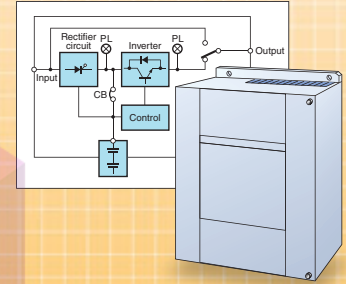

Discrete IGBT Trend

► For general-purpose inverters

Our 3rd generation low-loss and low-noise IGBTs are ideal for inverter applications to reduce switching loss and thus improve energy efficiency. The following graphs compare the thermal and turn-on characteristics of our 3rd generation IGBTs and 500-V MOSFETs

► IC - V_{CE} Temperature Characteristics

Low saturation voltage with minimal temperature dependence

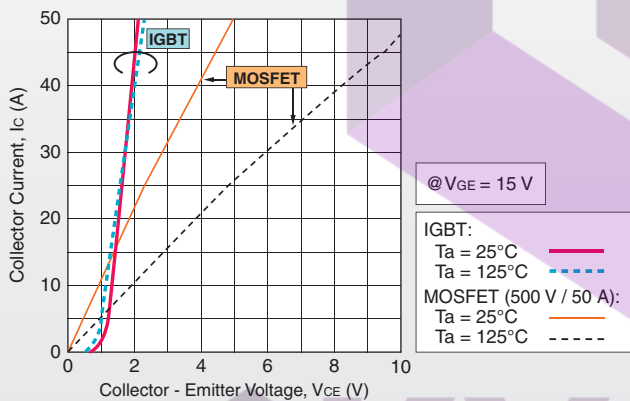

► Turn-On Waveform

Fast reverse-recovery characteristics due to built-in diode with optimal characteristics

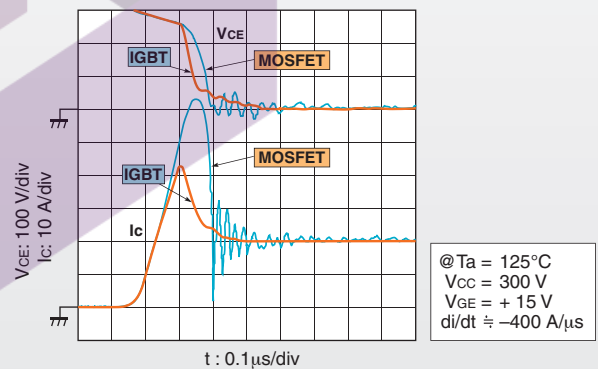

► Power Loss vs. Carrier Frequency Characteristics

Simulation data for inverter applications

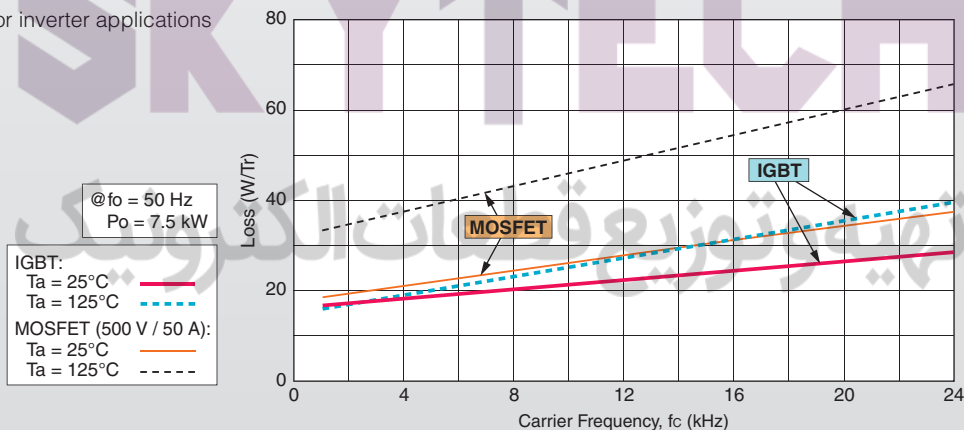

5-1 General-Purpose Inverter

Product Lineup

► For general-purpose inverters

► Circuit Configurations

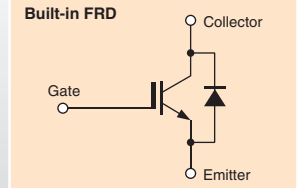
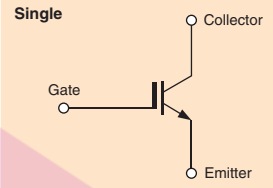

600-V and 1200-V IGBTs

Main Applications	Features	Part Number	Absolute Maximum Ratings				Package	Circuit Configuration (*1)	V _{CE(sat)} Typ.			t _r Typ.		Remarks
			V _{CEs} (V)	I _c		P _c T _c = 25°C (W)			@ I _c (A)	@ V _{GE} (V)	μs	Load (*2)		
				DC (A)	Pulsed (A)									
Motor driving (UPS/PFC)	High V _{CEs} (1200V)	GT10Q101	1200	10	20	140	TO-3P(N)	◆	2.1	10	15	0.16	L	
		GT10Q301	1200	10	20	140	TO-3P(N)	Built-in FRD	2.1	10	15	0.16	L	
		GT15Q102	1200	15	30	170	TO-3P(N)	◆	2.1	15	15	0.16	L	
		GT15Q301	1200	15	30	170	TO-3P(N)	Built-in FRD	2.1	15	15	0.16	L	
		GT25Q102	1200	25	50	200	TO-3P(LH)	◆	2.1	25	15	0.16	L	
		GT25Q301	1200	25	50	200	TO-3P(LH)	Built-in FRD	2.1	25	15	0.16	L	
	High V _{CEs} (600V)	GT10J301	600	10	20	90	TO-3P(N)	Built-in FRD	2.1	10	15	0.15	L	
		GT20J101	600	20	40	130	TO-3P(N)	◆	2.1	20	15	0.15	L	
		GT20J301	600	20	40	130	TO-3P(N)	Built-in FRD	2.1	20	15	0.15	L	
		GT30J101	600	30	60	155	TO-3P(N)	◆	2.1	30	15	0.15	L	
GT30J301		600	30	60	155	TO-3P(N)	Built-in FRD	2.1	30	15	0.15	L		
		GT50J102	600	50	100	200	TO-3P(LH)	◆	2.1	50	15	0.15	L	

600-V Fast IGBTs (4th Generation)

(FS: Fast Switching)

Main Applications	Features	Part Number	Absolute Maximum Ratings				Package	Circuit Configuration (*1)	V _{CE(sat)} Typ.			t _r Typ.		Remarks
			V _{CEs} (V)	I _c		P _c T _c = 25°C (W)			@ I _c (A)	@ V _{GE} (V)	μs	Load (*2)		
				DC (A)	Pulsed (A)									
Inverter power supplies (UPS/PFC/motor)	Fast switching	GT30J121	600	30	60	170	TO-3P(N)	◆	2.0	30	15	0.05	L	
		GT30J126	600	30	60	90	TO-3P(N)IS	◆	1.95	30	15	0.05	L	Isolation Package
		GT30J324	600	30	60	170	TO-3P(N)	Built-in FRD	2.0	30	15	0.05	L	
		GT50J121	600	50	100	240	TO-3P(LH)	◆	2.0	50	15	0.05	L	
		GT50J325	600	50	100	240	TO-3P(LH)	Built-in FRD	2.0	50	15	0.05	L	

600-V IGBTs for Low Frequency Switching

Main Applications	Features	Part Number	Absolute Maximum Ratings				Package	Circuit Configuration (*1)	V _{CE(sat)} Typ.			t _r Typ.		Remarks
			V _{CEs} (V)	I _c		P _c T _c = 25°C (W)			@ I _c (A)	@ V _{GE} (V)	μs	Load (*2)		
				DC (A)	Pulsed (A)									
Power factor correction	Low-frequency switching	GT30J122	600	30	100	75	TO-3P(N)IS	◆	2.1	50	15	0.25	R	Partial Switching Converter
		GT30J122A	600	30	100	120	TO-3P(N)	◆	1.7	50	15	0.2	R	Partial Switching Converter
		GT40J121	600	40	100	80	TO-3P(N)IS	◆	1.45	40	15	0.2	R	Partial Switching Converter

*1 ◆ : Single
FRD: Fast Recovery Diode

*2 R : Resistive load
L : Inductive load

◆ : New product

5-2 Soft-Switching Applications

Static inverters in IH cooktops, IH rice cookers and microwave ovens utilize a soft-switching technique which exhibits low switching loss. Toshiba offers IGBTs suitable for soft-switching applications.

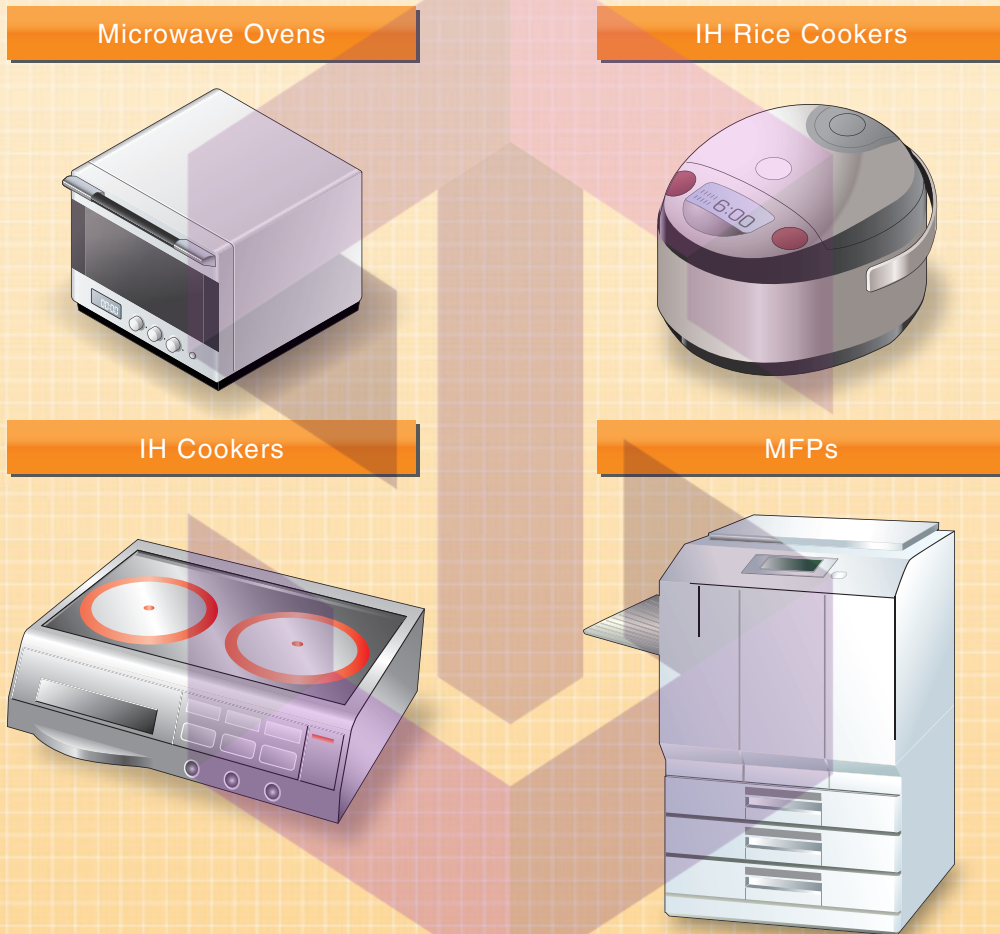

AC Input Voltage	Circuit	IGBT Rating
100 V to 120 V	<p>Voltage Resonance</p> <p>Waveform</p>	<p>$V_{CES} = 900 \text{ V to } 1050 \text{ V}$ $I_c = 15 \text{ A to } 60 \text{ A}$</p>
200 V to 240 V	<p>Waveform</p>	<p>$V_{CES} = 1200 \text{ V to } 1500 \text{ V}$ $I_c = 40 \text{ A}$</p>
100 V to 240 V	<p>Current Resonance</p> <p>Waveform</p>	<p>$V_{CES} = 600 \text{ V}$ $I_c = 30 \text{ A to } 60 \text{ A}$</p>

IH: Induction heating
MFP: Multifunction Printer

5-2 Soft-Switching Applications

6.5th-Generation RC-IGBT Series (New Products)

The RC-IGBT (Reverse-Conducting IGBT) Series consists of a freewheeling diode monolithically integrated in an IGBT chip. This is realized by forming an N layer through the P layer on the collector side. The RC-IGBT Series is environmentally friendly since it eliminates the need for a separate diode. Additionally, it also features a reduced thermal resistance of the freewheeling diode.

Cross-Sectional View of the RC-IGBT

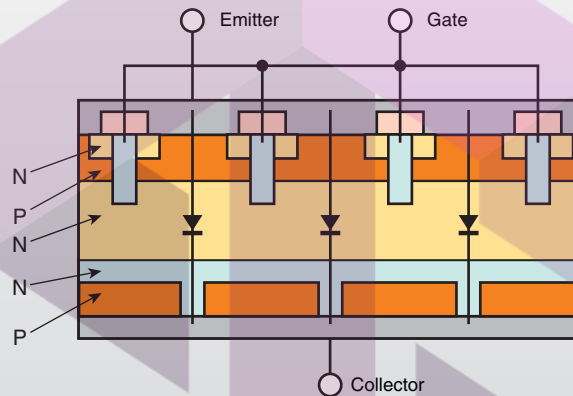

Product Lineup

► For soft switching

Main Applications	Features	Part Number	Absolute Maximum Ratings					Package	Circuit Configuration (*1)	V _{CE(sat)} Typ. @ Ta = 25°C			t _r Typ. @ Ta = 25°C		Remarks	
			V _{CES} (V)	I _c		P _c				I _c (A)	V _{GE} (V)	t _r (μs)	Load (*2)			
				DC (A)	Pulsed (A)	T _c = 25°C (W)	T _j (°C)									
IH rice cookers and IH cooktops	AC 100 V	Voltage resonance	GT35MR21	900	35	100	82	150	TO-3P(N)IS	Built-in FWD	1.6	35	15	0.2	R	6.5th generation
			GT50MR21	900	50	100	230	175	TO-3P(N)	Built-in FWD	1.7	50	15	0.18	R	6.5th generation T _j = 175°C
	GT50NR21	1050	50	100	230	175	TO-3P(N)	Built-in FWD	1.8	50	15	0.2	R	6.5th generation T _j = 175°C		
	AC 200 V	GT40QR21	1200	40	80	230	175	TO-3P(N)	Built-in FWD	1.9	40	15	0.2	R	6.5th generation T _j = 175°C	

*1 Abbreviation in the "Circuit Configuration" column
FWD: Free-Wheeling Diode

*2 Abbreviation in the "Load" column
R : Resistive load

◻ : New product

تهیه و توزیع قطعات الکترونیک

► Circuit Configurations

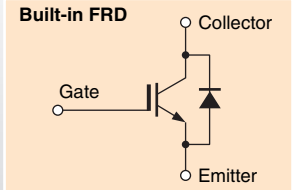
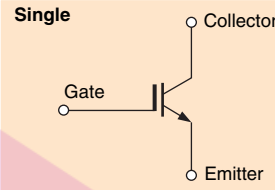

IGBTs for Soft-Switching Applications

Main Applications	Features	Part Number	Absolute Maximum Ratings					Package	Circuit Configuration (*1)	V _{CE(sat)} Typ.			t _r Typ.		Remarks	
			V _{CE(s)} (V)	I _c		P _c T _c = 25°C (W)	T _j (°C)			@ I _c (A)	@ V _{GE} (V)	tr (μs)	Load (*2)			
				DC (A)	Pulsed (A)											
IH rice cookers and IH cooktops	AC 200 V	Current resonance	GT30J322	600	30	100	75	150	TO-3P(N)IS	Built-in FRD	2.1	50	15	0.25	R	
			GT35J321	600	37	100	75	150	TO-3P(N)IS	Built-in FRD	1.9	50	15	0.19	R	
			GT40J321	600	40	100	120	150	TO-3P(N)	Built-in FRD	2.0	40	15	0.11	R	Fast switching
			GT40J322	600	40	100	120	150	TO-3P(N)	Built-in FRD	1.7	40	15	0.2	R	
			GT40J323	600	40	100	170	150	TO-3P(N)	Built-in FRD	2.0	40	15	0.06	R	Fast switching
			GT40J325	600	40	100	80	150	TO-3P(N)IS	Built-in FRD	1.45	40	15	0.2	R	6th generation
			GT50J322	600	50	100	130	150	TO-3P(LH)	Built-in FRD	2.1	50	15	0.25	R	
			GT50J322H	600	50	100	130	150	TO-3P(LH)	Built-in FRD	2.2	50	15	0.11	R	Fast switching
			GT50J327	600	50	100	140	150	TO-3P(N)	Built-in FRD	1.9	50	15	0.19	R	
			GT50J341	600	50	100	200	175	TO-3P(N)	Built-in FRD	1.6	50	15	0.15	R	6th generation T _j = 175°C
			GT50J328	600	50	120	140	150	TO-3P(N)	Built-in FRD	2.0	50	15	0.10	R	Fast switching
			GT60J321	600	60	120	200	150	TO-3P(LH)	Built-in FRD	1.55	60	15	0.30	R	
			GT60J323	600	60	120	170	150	TO-3P(LH)	Built-in FRD	1.9	60	15	0.16	R	
			GT60J323H	600	60	120	170	150	TO-3P(LH)	Built-in FRD	2.1	60	15	0.12	R	Fast switching
AC 100 V	Voltage resonance	GT15M321	900	15	30	55	150	TO-3P(N)IS	Built-in FWD	1.8	15	15	0.20	R		
		GT50M322	900	50	120	156	150	TO-3P(N)	Built-in FWD	2.1	60	15	0.25	R		
		GT60M324	900	60	120	254	175	TO-3P(N)	Built-in FWD	1.7	60	15	0.11	R	T _j = 175°C	
		GT50N322A	1000	50	120	156	150	TO-3P(N)	Built-in FWD	2.2	60	15	0.10	R	Fast switching	
		GT50N324	1000	50	120	150	150	TO-3P(N)	Built-in FWD	1.9	60	15	0.11	R	6th generation	
		GT60N321	1000	60	120	170	150	TO-3P(LH)	Built-in FWD	2.3	60	15	0.25	R		
AC 200 V		GT40T321	1500	40	80	230	175	TO-3P(N)	Built-in FWD	2.15	40	15	0.24	R	T _j = 175°C	

*1 Abbreviations in the "Circuit Configuration" column
FRD: Fast Recovery Diode, FWD: Free-Wheeling Diode
*2 Abbreviation in the "Load" column
R : Resistive load

■ : New product

تهیه و توزیع قطعات الکترونیک

5-2 Soft-Switching Applications

► Comparisons Between Hard and Soft Switching (diagrams shown only as a guide)

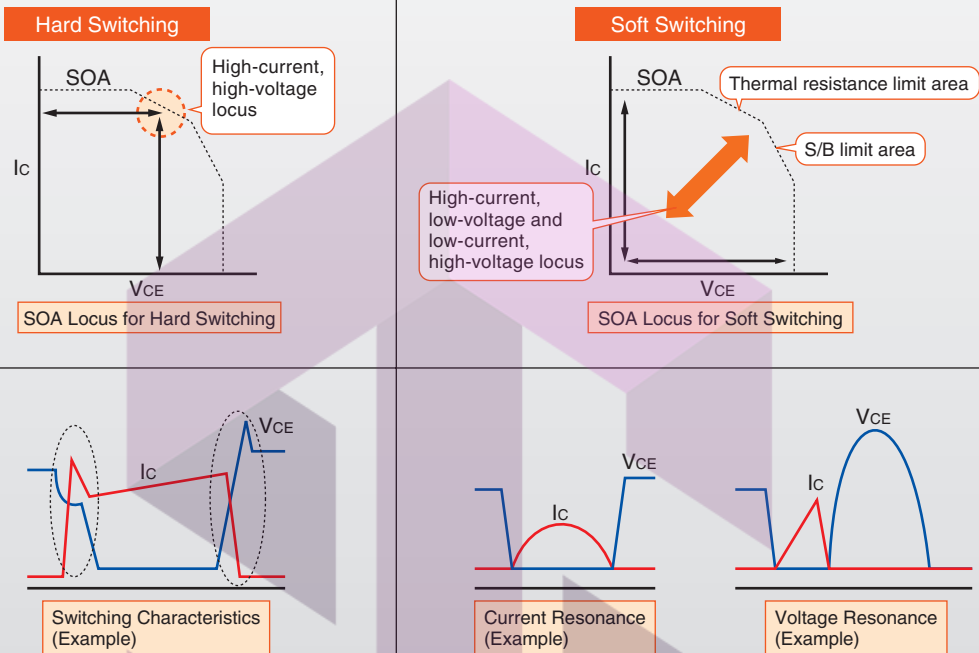

5-3 Strobe Flash Applications

Strobe flash control is now prevalent in digital still cameras. Package sizes are getting smaller, and logic levels are increasingly used to represent the gate drive voltage. Toshiba offers compact IGBTs featuring low gate drive voltage.

- As a voltage-controlled device, the IGBT requires only a few components for drive circuit.
- IGBTs require fewer components for the strobe flash circuit (compared to SCRs).
- Strobe flash IGBTs are capable of switching large currents.

DSC, Compact Camera

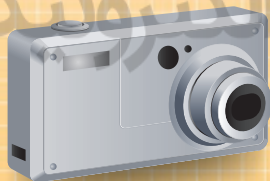

Single-Lens Reflex Camera

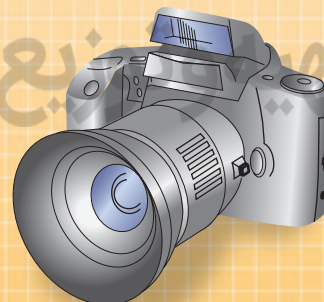

5-3 Strobe Flash Applications

Product Lineup

► For strobe flashes

2.5-V to 4.0-V Gate Drive Series

The IGBT can operate with a gate drive voltage of 2.5 V to 4.0 V. The common 3.3-V or 5-V internal power supply in a camera can be used as a gate drive power supply to simplify the power supply circuitry. A zener diode is included between the gate and emitter to provide ESD surge protection.

► Example of an IGBT Gate Drive Circuit (3.3-V Power Supply)

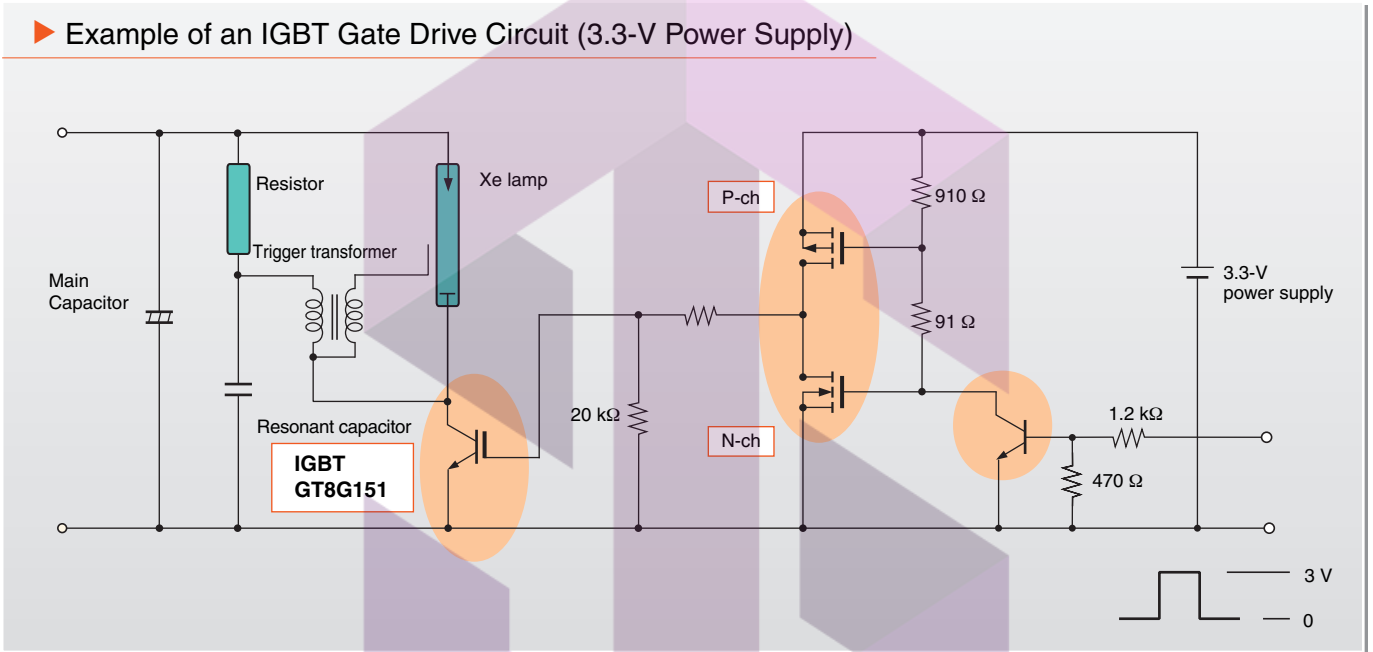

3.3-V Power Supply

Part Number	V _{CE} / I _C	Gate Drive Voltage Min (V)	V _{CE(sat)} (V)		P _C (W) @ T _a = 25°C	Package	Remarks
			Typ.	V _{GE} / I _C			
GT5G133	400 V / 130 A	2.5	3.0	2.5 V / 130 A	0.83	TSON-8	7th generation
GT8G151	400 V / 150 A	2.5	2.65	2.5 V / 150 A	0.83	TSON-8	7th generation

 : New product

5-V Power Supply

Part Number	V _{CE} / I _C	Gate Drive Voltage Min (V)	V _{CE(sat)} (V)		P _C (W) @ T _a = 25°C	Package	Remarks
			Typ.	V _{GE} / I _C			
GT8G132	400 V / 150 A	4.0	2.3	4.0 V / 150 A	1.1	SOP-8	5th generation
GT10G131	400 V / 200 A	4.0	2.3	4.0 V / 200 A	1.9	SOP-8	5th generation

<Connection Examples>

Board connection example

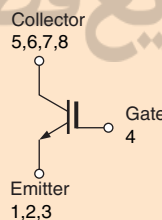

All the emitter terminals should be connected together.

5-4 Plasma Display Panel Applications

Plasma Displays

Parallel MOSFETs have been used for the drive circuitry of plasma display panels (PDPs). Recently, however, IGBTs are commonly used in large current applications due to their superior current conduction capability.



Example of a Plasma Display Panel Drive Circuit

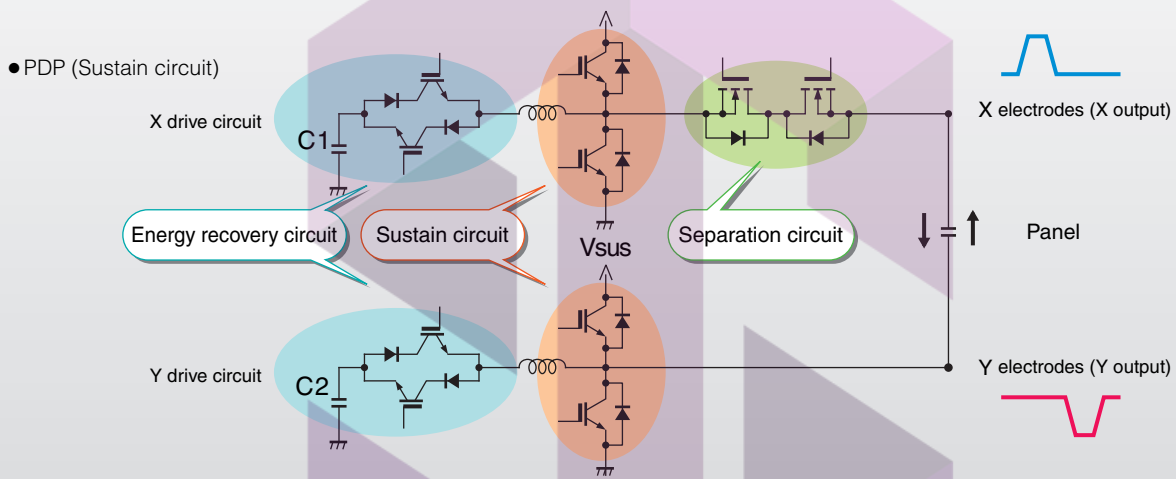

Product Lineup

► For plasma display panels

300-V IGBTs

Part Number	$V_{CES} / I_{cp} @ 3 \mu s$	$V_{CE(sat)} (V) \text{ Typ. } @ 120 A$	$P_c (W) @ T_c = 25^\circ C$	Package	Remarks
GT30F124	300 V / 200 A	2.3	25	TO-220SIS	6th generation
GT30F125	330 V / 200 A	1.9	25	TO-220SIS	6th generation
GT45F127	300 V / 200 A	1.6	26	TO-220SIS	6th generation
GT45F128	330 V / 200 A	1.45	26	TO-220SIS	6th generation
GT30F131	360 V / 200 A	1.9	140	TO-220SM(MXN)	6th generation

■ : New product

400-V IGBTs

Part Number	$V_{CES} / I_{cp} @ 3 \mu s$	$V_{CE(sat)} (V) \text{ Typ. } @ 120 A$	$P_c (W) @ T_c = 25^\circ C$	Package	Remarks
GT30G124	430 V / 200 A	2.5	25	TO-220SIS	6th generation
GT30G125	430 V / 200 A	2.1	25	TO-220SIS	6th generation
GT45G127	430 V / 200 A	1.7	26	TO-220SIS	6th generation
GT45G128	430 V / 200 A	1.55	26	TO-220SIS	6th generation

■ : New product

600-V IGBTs

Part Number	$V_{CES} / I_{cp} @ 3 \mu s$	$V_{CE(sat)} (V) \text{ Typ. } @ 120 A$	$P_c (W) @ T_c = 25^\circ C$	Package	Remarks
GT30J124	600 V / 200 A	2.4	26	TO-220SIS	5th generation

6 Package Dimensions

Unit: mm

▶ SOP-8

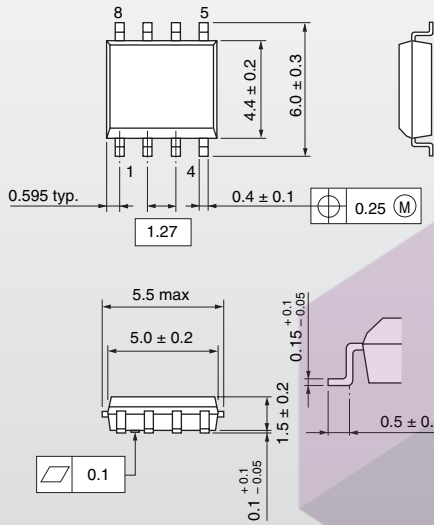

- 1, 2, 3. Emitter
- 4. Gate
- 5, 6, 7, 8. Collector

▶ TSON-8

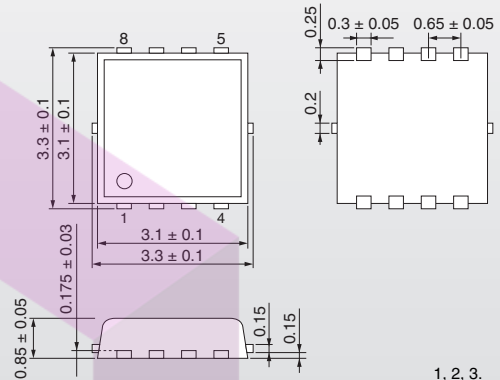

- 1, 2, 3. Emitter
- 4. Gate
- 5, 6, 7, 8. Collector

▶ TO-220SM(MXN)

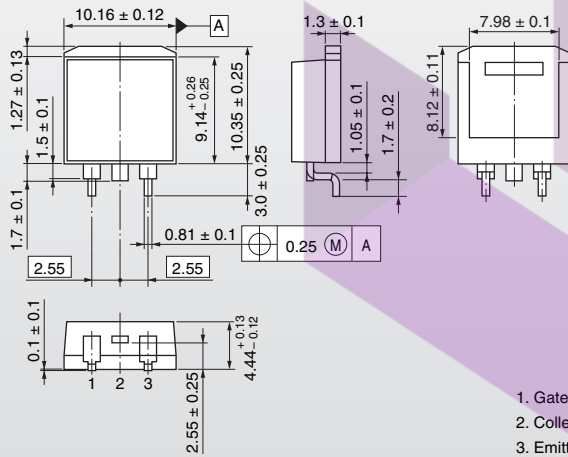

- 1. Gate
- 2. Collector
- 3. Emitter

SKYTECH

تهیه و توزیع قطعات الکترونیک

6 Package Dimensions

Unit: mm

▶ TO-220SIS

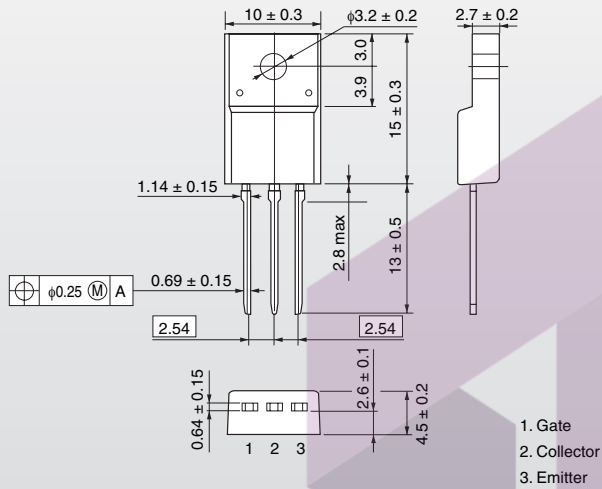

▶ TO-3P(N)

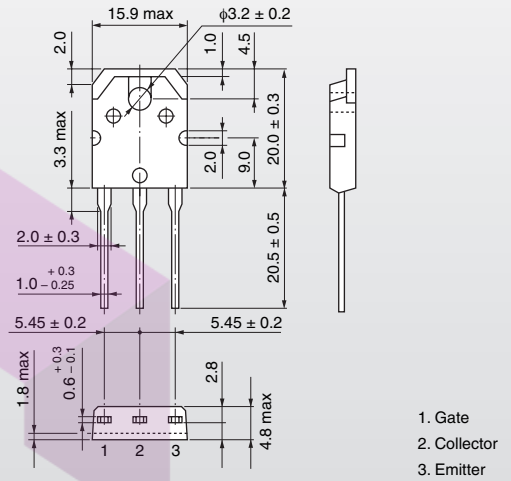

▶ TO-3P(LH)

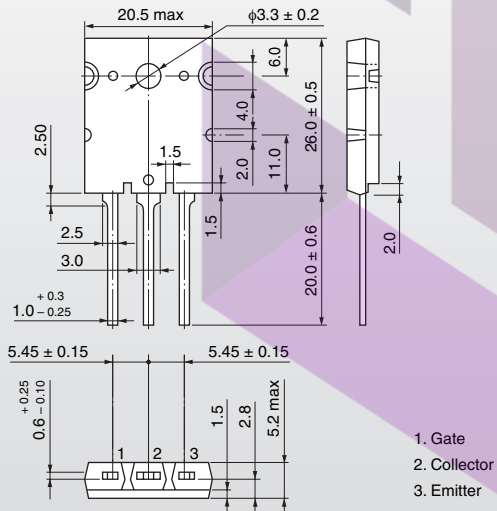

▶ TO-3P(N)IS

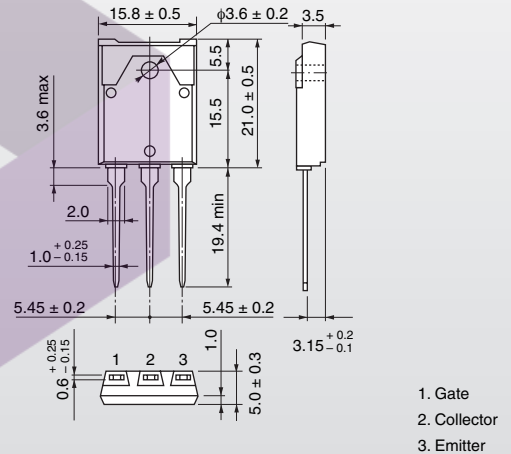

SKYTECH

تهیه و توزیع قطعات الکترونیک

7 Final-Phase and Obsolete Products

The following products are in stock but are being phased out of production. The recommended replacements that continue to be available are listed in the right-hand column. However, the characteristics of the recommended replacements may not be exactly the same as those of the final-phase and obsolete products. Before using a recommended replacement, be sure to check that it is suitable for use under the intended operating conditions.

Application	Final-Phase or Obsolete Product	Absolute Maximum Ratings		Package	Recommended Obsolete Replacements	Absolute Maximum Ratings		Package
		V _{CE} S (V)	I _C (A) DC			V _{CE} S (V)	I _C (A) DC	
Soft switching Resonant switching	MG30T1AL1	1500	30	IH	—	—	—	—
	MG60M1AL1	900	60	IH	—	—	—	—
	GT40M101	900	40	TO-3P(N)IS	—	—	—	—
	GT40M301	900	40	TO-3P(LH)	—	—	—	—
	GT40Q322	1200	39	TO-3P(N)	—	—	—	—
	GT40Q323	1200	39	TO-3P(N)	—	—	—	—
	GT40T101	1500	40	TO-3P(LH)	—	—	—	—
	GT40T301	1500	40	TO-3P(LH)	—	—	—	—
	GT50L101	800	50	TO-3P(L)	—	—	—	—
	GT50M101	900	50	TO-3P(L)	—	—	—	—
	GT50Q101	1200	50	IH	—	—	—	—
	GT50S101	1400	50	IH	—	—	—	—
	GT50T101	1500	50	IH	—	—	—	—
	GT60J101	600	60	TO-3P(L)	—	—	—	—
	GT60J322	600	60	TO-3P(LH)	—	—	—	—
	GT60M101	900	60	TO-3P(L)	—	—	—	—
	GT60M102	900	60	TO-3P(L)	—	—	—	—
	GT60M103	900	60	TO-3P(L)	—	—	—	—
	GT60M104	900	60	TO-3P(L)	—	—	—	—
	GT60M105	900	60	TO-3P(L)	—	—	—	—
	GT60M301	900	60	TO-3P(LH)	—	—	—	—
	GT60M302	900	60	TO-3P(LH)	—	—	—	—
	GT60M305	900	60	TO-3P(LH)	—	—	—	—
GT60M322	950	60	TO-3P(LH)	GT60N321	1000	60	TO-3P(LH)	
GT60N323	1050	60	TO-3P(LH)	—	—	—	—	
GT80J101	600	80	TO-3P(L)	—	—	—	—	
GT80J101A	600	80	TO-3P(LH)	—	—	—	—	
General-purpose motors General-purpose inverters	GT8J101	600	8	TO-220NIS	—	—	—	—
	GT8J102	600	8	TO-220SM	—	—	—	—
	GT8N101	1000	8	TO-3P(N)	GT10Q101	1200	10	TO-3P(N)
	GT8Q101	1200	8	TO-3P(N)	GT10Q101	1200	10	TO-3P(N)
	GT8Q102	1200	8	TO-220SM	—	—	—	—
	GT10Q311	1200	10	TO-3P(SM)	—	—	—	—
	GT15J101	600	15	TO-3P(N)	GT20J101	600	20	TO-3P(N)
	GT15J102	600	15	TO-220NIS	—	—	—	—
	GT15J103	600	15	TO-220SM	—	—	—	—
	GT15N101	1000	15	TO-3P(N)	GT15Q102	1200	15	TO-3P(N)
	GT15Q101	1200	15	TO-3P(N)	GT15Q102	1200	15	TO-3P(N)
	GT15Q311	1200	15	TO-3P(SM)	—	—	—	—
	GT20J311	600	20	TO-3P(SM)	—	—	—	—
	GT25H101	500	25	TO-3P(N)	GT30J121	600	30	TO-3P(N)
	GT25J101	600	25	TO-3P(N)	GT30J121	600	30	TO-3P(N)
	GT25J102	600	25	TO-3P(N)IS	GT30J126	600	30	TO-3P(N)IS
	GT25Q101	1200	25	TO-3P(LH)	GT25Q102	1200	25	TO-3P(LH)
	GT30J311	600	30	TO-3P(SM)	—	—	—	—
	GT50J101	600	50	TO-3P(L)	GT50J121	600	50	TO-3P(LH)
Strobe flashes	GT5G101	400	130 (pulsed)	NPM	—	—	—	—
	GT5G102	400	130 (pulsed)	DP	—	—	—	—
	GT5G103	400	130 (pulsed)	DP	—	—	—	—
	GT8G101	400	130 (pulsed)	NPM	—	—	—	—
	GT8G102	400	150 (pulsed)	NPM	—	—	—	—
	GT8G103	400	150 (pulsed)	DP	—	—	—	—
	GT8G121	400	150 (pulsed)	DP	—	—	—	—
	GT10G101	400	130 (pulsed)	TO-220NIS	—	—	—	—
	GT10G102	400	130 (pulsed)	TO-220NIS	—	—	—	—
	GT15G101	400	170 (pulsed)	TO-220NIS	—	—	—	—
	GT20G101	400	130 (pulsed)	TO-220FL	—	—	—	—
	GT20G102	400	130 (pulsed)	TO-220FL	—	—	—	—
	GT25G101	400	170 (pulsed)	TO-220FL	—	—	—	—
	GT25G102	400	150 (pulsed)	TO-220FL	—	—	—	—
	GT50G101	400	100 (pulsed)	TO-3P(N)	—	—	—	—
	GT50G102	400	100 (pulsed)	TO-3P(N)	—	—	—	—
Audio amps	GT75G101	400	150 (pulsed)	TO-3P(N)	—	—	—	—
	GT20D101	250	20	TO-3P(L)	—	—	—	—
	GT20D201	-250	-20	TO-3P(L)	—	—	—	—

Toshiba America Electronic Components, Inc.

- Irvine, Headquarters
Tel: (949)623-2900 Fax: (949)474-1330
- Buffalo Grove (Chicago)
Tel: (847)484-2400 Fax: (847)541-7287
- Duluth/Atlanta
Tel: (770)931-3363 Fax: (770)931-7602
- El Paso
Tel: (915)771-8156
- Marlborough
Tel: (508)481-0034 Fax: (508)481-8828
- Parsippany
Tel: (973)541-4715 Fax: (973)541-4716
- San Jose
Tel: (408)526-2400 Fax: (408)526-2410
- Wixom (Detroit)
Tel: (248)347-2607 Fax: (248)347-2602
- Bloomington
Tel: (952)842-2400 Fax: (952)893-8031
- San Diego
Tel: (858)385-5900 Fax: (858)674-7606

Toshiba Electronics do Brasil Ltda.

Tel: (011)2539-6681 Fax: (011)2539-6675

Toshiba Electronics Europe GmbH

- Düsseldorf Head Office
Tel: (0211)5296-0 Fax: (0211)5296-400
- France Branch
Tel: (1)47282181
- Italy Branch
Tel: (039)68701 Fax: (039)6870205
- Spain Branch
Tel: (91)660-6798 Fax: (91)660-6799
- U.K. Branch
Tel: (0870)060-2370 Fax: (01252)53-0250
- Sweden Branch
Tel: (08)704-0900 Fax: (08)80-8459

Toshiba Electronics Asia (Singapore) Pte. Ltd.

Tel: (6278)5252 Fax: (6271)5155

Toshiba Electronics Service (Thailand) Co., Ltd.

Tel: (02)501-1635 Fax: (02)501-1638

Toshiba Electronics Trading (Malaysia) Sdn. Bhd.

- Kuala Lumpur Head Office
Tel: (03)5631-6311 Fax: (03)5631-6307
- Penang Office
Tel: (04)226-8523 Fax: (04)226-8515

Toshiba India Private Ltd.

Tel: (0124)499-6600 Fax: (0124)499-6611

Toshiba Electronics Asia, Ltd.

- Hong Kong Head Office
Tel: 2375-6111 Fax: 2375-0969
- Beijing Office
Tel: (010)6590-8796 Fax: (010)6590-8791
- Chengdu Office
Tel: (028)8675-1773 Fax: (028)8675-1065
- Qingdao Office
Tel: (532)8579-3328 Fax: (532)8579-3329

Toshiba Electronics (Shenzhen) Co., Ltd.

Tel: (0755)2399-6897 Fax: (0755)2399-5573

Toshiba Electronics (Shanghai) Co., Ltd.

- Shanghai PUXI Branch
Tel: (021)6139-3888 Fax: (021)6190-8288
- Hangzhou Office
Tel: (0571)8717-5004 Fax: (0571)8717-5013

- Nanjing Office
Tel: (025)8689-0070 Fax: (025)8689-0070

Toshiba Electronics (Dalian) Co., Ltd.

Tel: (0411)8368-6882 Fax: (0411)8369-8282

Tsurong Xiamen Xiangyu Trading Co., Ltd.

Tel: (0592)226-1398 Fax: (0592)226-1399

Toshiba Electronics Korea Corporation

- Seoul Head Office
Tel: (02)3484-4334 Fax: (02)3484-4302
- Daegu Office
Tel: (053)428-7610 Fax: (053)428-7617

Toshiba Electronics Taiwan Corporation

- Taipei Head Office
Tel: (02)2508-9988 Fax: (02)2508-9999

- ▶ Toshiba Corporation, and its subsidiaries and affiliates (collectively "TOSHIBA"), reserve the right to make changes to the information in this document, and related hardware, software and systems (collectively "Product") without notice.
- ▶ This document and any information herein may not be reproduced without prior written permission from TOSHIBA. Even with TOSHIBA's written permission, reproduction is permissible only if reproduction is without alteration/omission.
- ▶ Though TOSHIBA works continually to improve Product's quality and reliability, Product can malfunction or fail. Customers are responsible for complying with safety standards and for providing adequate designs and safeguards for their hardware, software and systems which minimize risk and avoid situations in which a malfunction or failure of Product could cause loss of human life, bodily injury or damage to property, including data loss or corruption. Before customers use the Product, create designs including the Product, or incorporate the Product into their own applications, customers must also refer to and comply with (a) the latest versions of all relevant TOSHIBA information, including without limitation, this document, the specifications, the data sheets and application notes for Product and the precautions and conditions set forth in the "TOSHIBA Semiconductor Reliability Handbook" and (b) the instructions for the application with which the Product will be used with or for. Customers are solely responsible for all aspects of their own product design or applications, including but not limited to (a) determining the appropriateness of the use of this Product in such design or applications; (b) evaluating and determining the applicability of any information contained in this document, or in charts, diagrams, programs, algorithms, sample application circuits, or any other referenced documents; and (c) validating all operating parameters for such designs and applications. **TOSHIBA ASSUMES NO LIABILITY FOR CUSTOMERS' PRODUCT DESIGN OR APPLICATIONS.**
- ▶ Product is intended for use in general electronics applications (e.g., computers, personal equipment, office equipment, measuring equipment, industrial robots and home electronics appliances) or for specific applications as expressly stated in this document. Product is neither intended nor warranted for use in equipment or systems that require extraordinarily high levels of quality and/or reliability and/or a malfunction or failure of which may cause loss of human life, bodily injury, serious property damage or serious public impact ("Unintended Use"). Unintended Use includes, without limitation, equipment used in nuclear facilities, equipment used in the aerospace industry, medical equipment, equipment used for automobiles, trains, ships and other transportation, traffic signaling equipment, equipment used to control combustions or explosions, safety devices, elevators and escalators, devices related to electric power, and equipment used in finance-related fields. Do not use Product for Unintended Use unless specifically permitted in this document.
- ▶ Do not disassemble, analyze, reverse-engineer, alter, modify, translate or copy Product, whether in whole or in part.
- ▶ Product shall not be used for or incorporated into any products or systems whose manufacture, use, or sale is prohibited under any applicable laws or regulations.
- ▶ The information contained herein is presented only as guidance for Product use. No responsibility is assumed by TOSHIBA for any infringement of patents or any other intellectual property rights of third parties that may result from the use of Product. No license to any intellectual property right is granted by this document, whether express or implied, by estoppel or otherwise.
- ▶ **ABSENT A WRITTEN SIGNED AGREEMENT, EXCEPT AS PROVIDED IN THE RELEVANT TERMS AND CONDITIONS OF SALE FOR PRODUCT, AND TO THE MAXIMUM EXTENT ALLOWABLE BY LAW, TOSHIBA (1) ASSUMES NO LIABILITY WHATSOEVER, INCLUDING WITHOUT LIMITATION, INDIRECT, CONSEQUENTIAL, SPECIAL, OR INCIDENTAL DAMAGES OR LOSS, INCLUDING WITHOUT LIMITATION, LOSS OF PROFITS, LOSS OF OPPORTUNITIES, BUSINESS INTERRUPTION AND LOSS OF DATA, AND (2) DISCLAIMS ANY AND ALL EXPRESS OR IMPLIED WARRANTIES AND CONDITIONS RELATED TO SALE, USE OF PRODUCT, OR INFORMATION, INCLUDING WARRANTIES OR CONDITIONS OF MERCHANTABILITY, FITNESS FOR A PARTICULAR PURPOSE, ACCURACY OF INFORMATION, OR NONINFRINGEMENT.**
- ▶ Do not use or otherwise make available Product or related software or technology for any military purposes, including without limitation, for the design, development, use, stockpiling or manufacturing of nuclear, chemical, or biological weapons or missile technology products (mass destruction weapons). Product and related software and technology may be controlled under the Japanese Foreign Exchange and Foreign Trade Law and the U.S. Export Administration Regulations. Export and re-export of Product or related software or technology are strictly prohibited except in compliance with all applicable export laws and regulations.
- ▶ Product may include products subject to foreign exchange and foreign trade control laws.
- ▶ Please contact your TOSHIBA sales representative for details as to environmental matters such as the RoHS compatibility of Product. Please use Product in compliance with all applicable laws and regulations that regulate the inclusion or use of controlled substances, including without limitation, the EU RoHS Directive. TOSHIBA assumes no liability for damages or losses occurring as a result of noncompliance with applicable laws and regulations.

